

L-Ring Effect on Air-Cooled Two-Stroke Gasoline Engines

Shoichi Furuhashi and Hiroshi Ichikawa

Dept. of Mechanical Engineering, Musashi Institute of Technology, Tokyo

A PISTON RING which has L-shape cross section is called an L-ring. Recently, it has been used for some air-cooled two-stroke gasoline engines with a good engine performance obtained. The reason for this L-ring effect has not been made clear up to date.

High-power two-stroke gasoline engines have been used for small cars, motorcycles, outboard motors, snowmobiles, and so on. These vehicles require their engines to endure higher thermal loads for a long time. Therefore, the maximum power of the engine is limited practically by its endurance against the thermal load. The piston and cylinder temperatures become the most important factors to the engine performance.

In this paper, a solution of the L-ring effects is examined by piston temperature measurement.

INFLUENCE OF PISTON AND CYLINDER TEMPERATURE ON THE ENGINE ENDURANCE LIMIT

Fig. 1 is an example of the temperature distribution of the piston and cylinder for a small size air-cooled two-stroke engine. It shows that the parts of piston and cylinder attain so high a temperature that the running endangers itself when in high power and low velocity of the vehicle. From many experiences, it has been determined that about 350 C for piston and 250 C for cylinder are the critical temperatures for the lubricating surfaces.

An experiment on piston seizure was carried out using the engine mentioned above with the same pistons and different

bore cylinders. Then the pistons were overheated owing to the lower velocity of cooling air. Fig. 2 shows the effect of piston clearance upon resistance against seizure. When load and speed are the same, the larger the piston clearance and the higher the temperature. That is, a large clearance piston has an inferior cooling effect because the heat transfer from the piston to the cylinder is low, and a large amount of gas flows through the clearance. In the case of this experiment, the pistons were seized by the cylinder regardless of the clearance when the cylinder temperature at point A reached about 260 C.

Another example of seizure is shown in Fig. 3. These pistons were used in a 440 cm³ (D × S = 66 × 44 mm) engine; a two-cylinder air-cooled two-stroke engine, made inferior in the gas tightness by enlarging the gap clearance of piston ring.

From this experiment, it is also certain that with the larger clearance, the pistons suffer more severe seizure than the pistons with smaller clearance. The cause of the seizure, therefore, is not the thermal expansion of piston, but it deteriorates the rubbing surfaces and lubricating oil at such a high temperature.

SEALING EFFECT OF L-RING

DYKES' THEORY ON L-RING - The L-ring was researched by Dykes (1)* in former times. In his research of L-ring,

*Numbers in parentheses designate References at end of paper.

ABSTRACT

An L-ring (a piston ring with an L-shaped cross section) has been used on some air-cooled two-stroke gasoline engines. Good performance has been obtained; the reason is unknown. The maximum power of these small engines (used mainly for small cars, motorcycles, outboard motors, snowmobiles, etc.)

is limited by its thermal load endurance. So piston and cylinder become the most important factors to the engine's performance. L-ring effects are examined in the light of these temperature measurements.

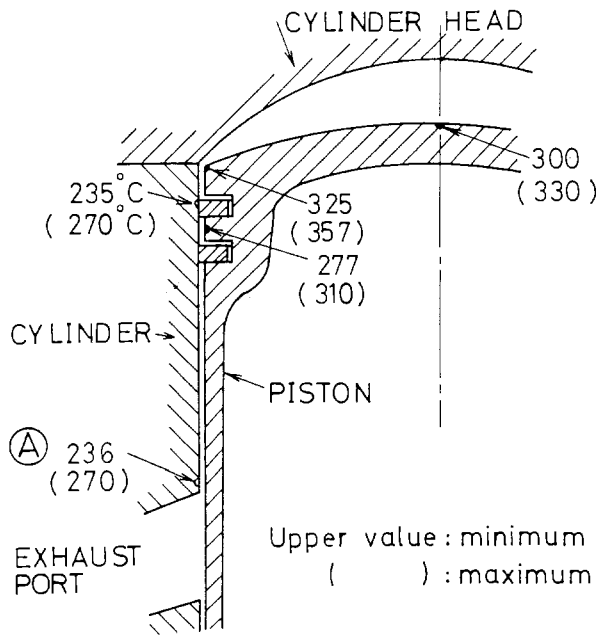

Fig. 1 - Temperature distribution on exhaust port side of 50 cm³ motorcycle; air-cooled two-stroke, under full load at 6000 rpm and 40 km/h cooling air

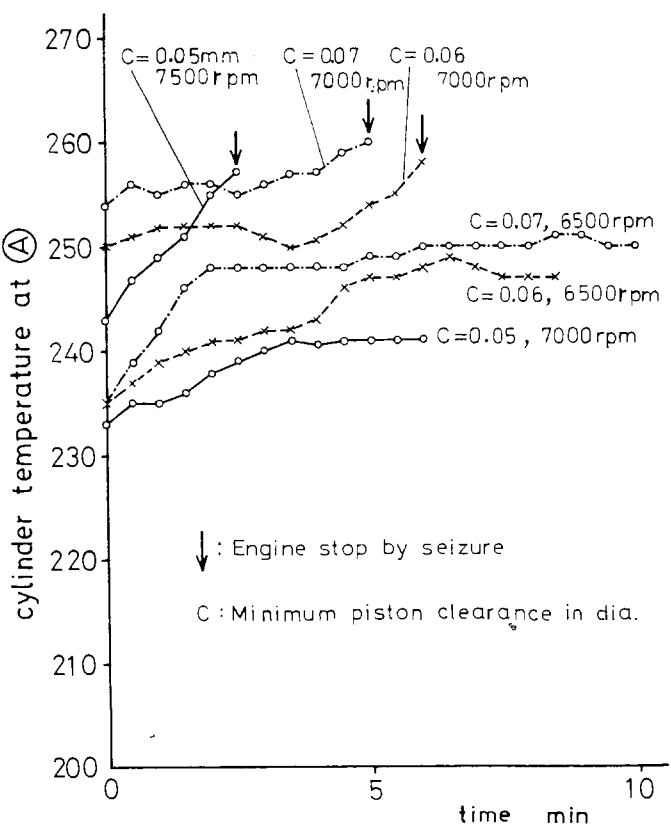
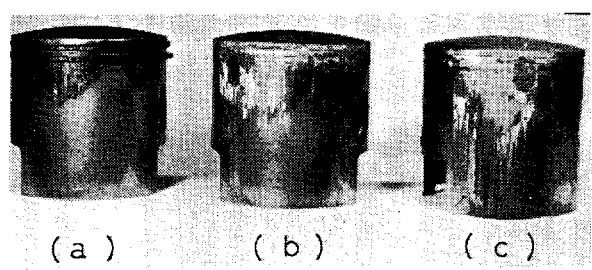

Fig. 2 - Effect of piston clearance upon seizure under full load and 20 km/h cooling air



- N Normal rings and normal clearance cylinder
- (a) Large gap rings and normal clearance cylinder
- (b) Large gap rings and 0.05mm over size cylinder
- (c) Large gap rings and 0.10mm over size cylinder

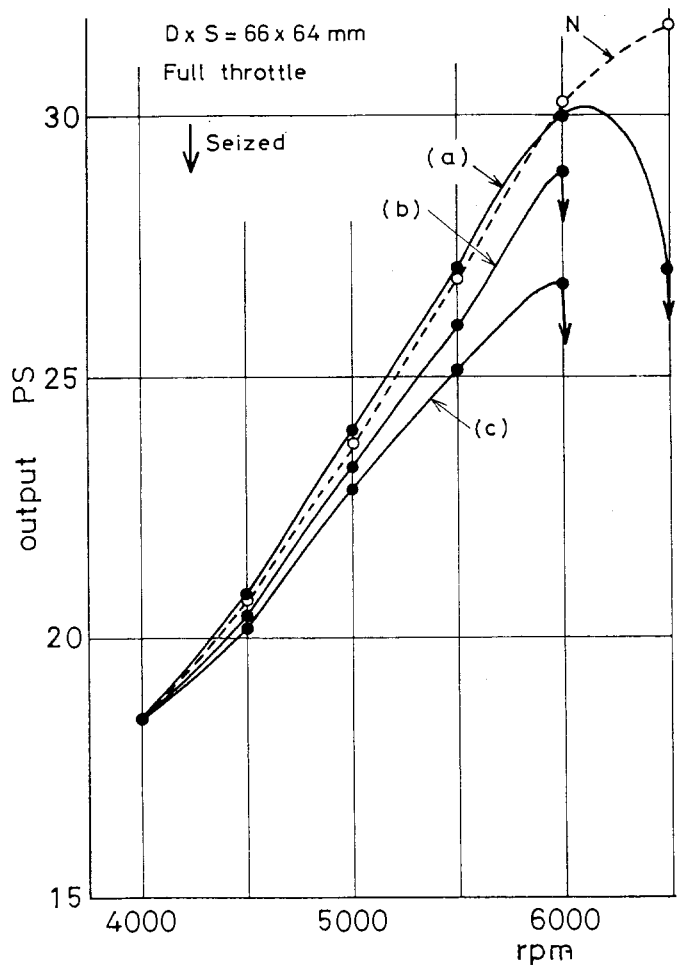

Fig. 3 - Seized pistons of 440 cm³ snowmobile engine and engine performance. A - Seized pistons; B - Maximum output with seized piston

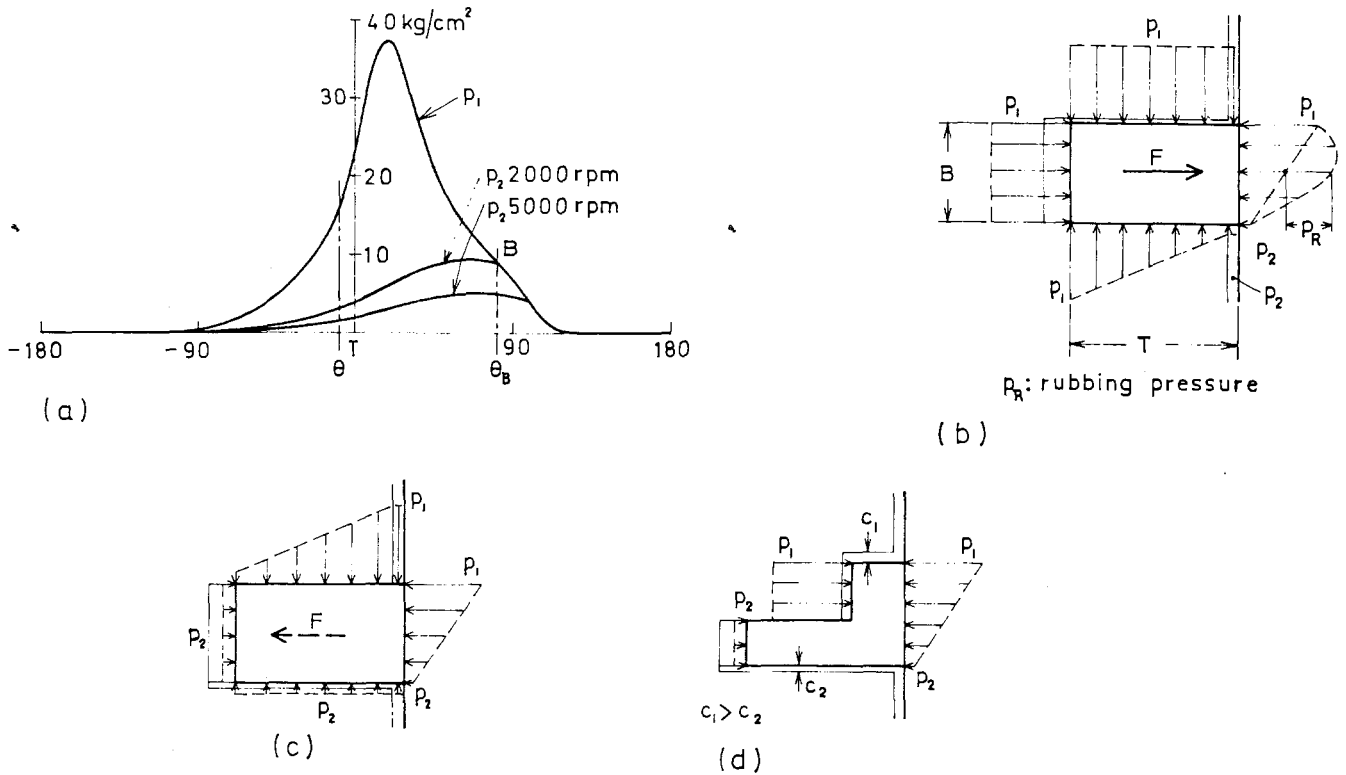

Fig. 4 - Pressure distribution around top ring. A - Pressures upper and lower the top ring; B - Lower surface contact; C - Upper surface contact; D - L-ring

Dykes emphasized on sealing effect of L-ring as follows: when a ring makes contact with the lower surface of the groove, the radial pressure distribution is explained as shown in Fig. 4B (2), where the force acting to the cylinder surface is

$$F = Bp_e + Bp_1 - B\left(\frac{p_1 + p_2}{2}\right) = B\left(p_e + \frac{p_1 - p_2}{2}\right) \quad (1)$$

where:

p_e = elastic pressure of the ring.

It must be balanced to the hydrodynamic lubricating load capacity, that is

$$F = \int_0^B p_R dx \quad (2)$$

So the ring never goes away from the cylinder surface.

If the ring lifted up and made contact with the upper surface of the groove by an inertial and frictional force, in spite of the large pressure difference ($p_1 - p_2$), the pressure distribution would change as shown in Fig. 4C. In this case, the direction of radial force would turn inward and its force would be

$$F = B\left(\frac{p_1 + p_2}{2}\right) - B(p_e + p_2) = B\left(\frac{p_1 - p_2}{2} - p_e\right) \quad (3)$$

So the ring would go away from the cylinder surface, and blowby would increase excessively. It is understood from Fig. 4D that the L-ring seems to be an effective countermeasure for avoiding this danger.

In general, however, this phenomenon never occurs. The first reason is that the top ring does not lift up at the wide open throttle running, even at very high speed. When a friction and conglutination force are neglected, the lift up of the piston ring must occur under the following condition:

$$\frac{W}{g} \alpha > \left(\frac{p_1 - p_2}{2}\right) T \quad \text{or} \quad \frac{B\gamma}{g} \alpha > \frac{p_1 - p_2}{2} \quad (4)$$

where:

γ = density of ring material
 α = acceleration of the ring

Fig. 5 shows a comparison of each value of the left and right side of Eq. 4 (calculated from Fig. 4A). It is understood that the top ring never lifts up. For the second reason, even if a ring lifted up, it does not go inward from the cylinder wall so far as elastic pressure p_e is larger than the $(p_1 - p_2)/2$; that is

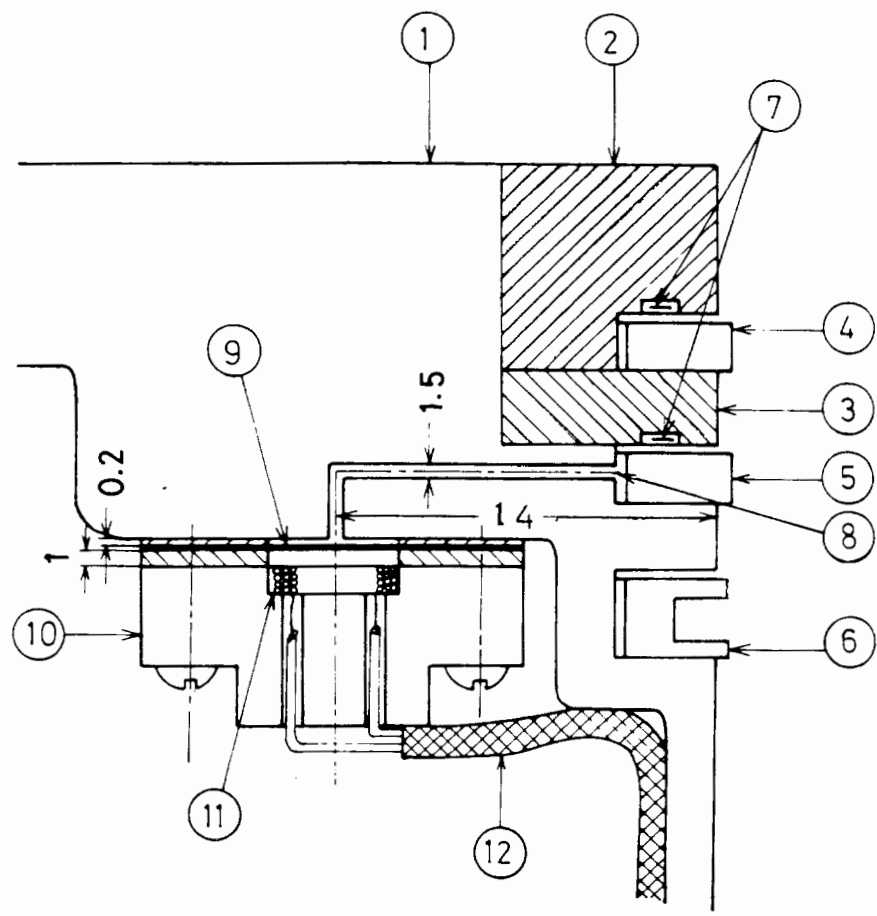

- 1. Piston body
- 2. Separate piece of top land
- 3. Separate piece of second land
- 4. Top ring
- 5. Second ring
- 6. Oil ring
- 7. Electrode for capacitance
- 8. p_2 gas passage
- 9. Elastic plate for p_2 measurement
- 10. Bakelite piece
- 11. Coil
- 12. Lead wires

Fig. 6 - Test piston consisted of three pieces

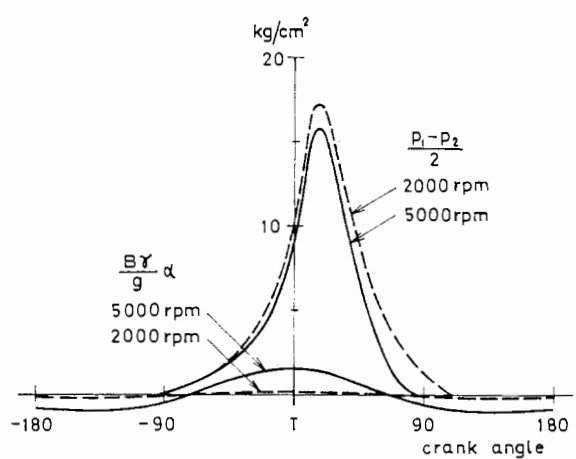

Fig. 5 - Comparison of axial forces of pressure and inertia to ring

$$p_e > \frac{P_1 - P_2}{2} \tag{5}$$

from Eq. 3.
It is possible for a ring to lift up and also to go inward only when the condition fulfills Eqs. 4 and 5 at the same time. That is:

$$\frac{B\gamma}{g} > \frac{P_1 - P_2}{2} > p_e \tag{6}$$

In order that the ring detaches itself from the cylinder wall, p_e should be smaller than $\frac{B\gamma}{g}\alpha$.

For example, $B = 0.2$ cm, $\gamma = 0.0073$ kg/cm³, and $\alpha = 1000$ g, then $1.46 > p_e$ kg/cm². After all, in the case of usual rectangular top ring, it never lifts up and never goes away; therefore, excessive blowby never occurs. On this point, the L-ring effect is out of discussion.

LOWER SURFACE CONTACT OF L-RING TO THE GROOVE - On the other hand, as the L-ring, to make matters worse, has a weakpoint (which will be described below), it must be used carefully.

Axial movements of some piston rings have been measured by a special device [Fig. 6(3)] in a water-cooled four-stroke automobile gasoline engine. Fig. 7 shows a typical record of axial movements of two rings and changes of pressure p_1 and p_2 .

Fig. 8 shows a record of the rectangular rings of $p_e = 1.7$ kg/cm², in which it is clarified that the top ring does not lift up until high speed. Fig. 9 shows a case of L-ring as the top ring with large elastic pressure $p_e (= 2.4$ kg/cm²). The uppermost line of Fig. 10 is a typical movement of L-ring. Only at position c in Fig. 10, in which the pressure p_1 is high, does the lower surface of the L-ring make contact completely with the

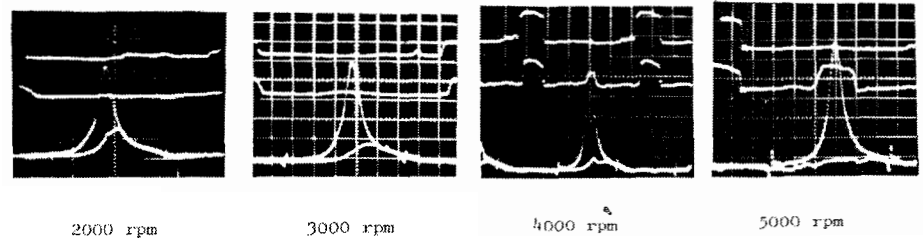

Fig. 8 - Effect of engine speed under full load ring in case of rectangular

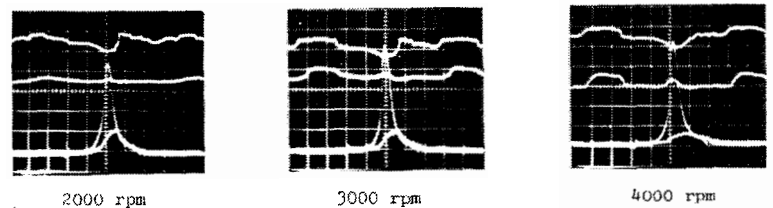

Fig. 9 - Movement of strong L-ring (as a top ring) under full load

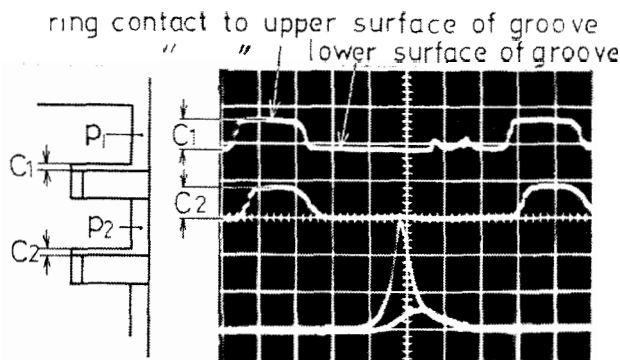

Fig. 7 - Typical record with rectangular rings

groove surface. At position b in Fig. 10, it does not make contact because the L-ring deforms in arch-shape in the cylinder (Fig. 11) by the elastic force. So that, at position b in Fig. 10, the blowby through the L-ring may increase.

Using a weak L-ring ($p_e = 0.38 \text{ kg/cm}^2$), however, as the deformation is small, the contact of the lower surface of L-ring is improved (Fig. 12).

Lastly, the amount of blowby is measured in the same engine as above, with pistons having only one compression ring. As a result, the deformation effect of L-ring on the blowby is proved again (Fig. 13). In this figure, "Lap" means that the ring is finished with lapping its lower surface after inserting the ring into a lapping device whose bore is coincident with that of the test engine cylinder. That is, the L-ring is not more effective in gas tightness than the usual rectangular ring; and the weaker in elastic pressure the L-ring is, the more it approaches the rectangular ring in gas tightness.

L-RING EFFECT ON OUTPUT PERFORMANCE

TEST ENGINE - For the purpose of this experiment, two types of two-stroke gasoline engines were used.

Type A - Two cylinders ($D \times S = 61.5 \times 60 \text{ mm}$), 360 cm^3 , air-cooled light car engine.

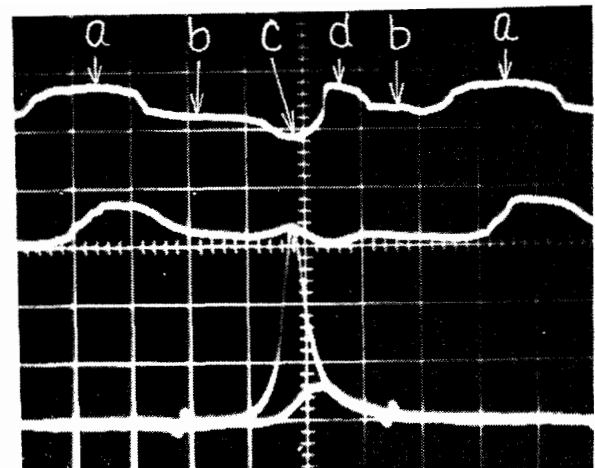

Fig. 10 - Typical movement of L-ring

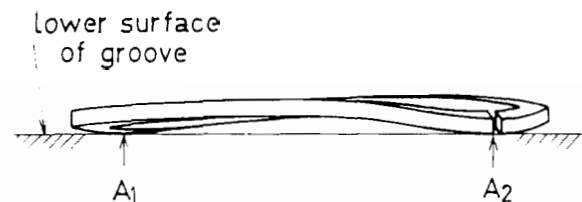

Fig. 11 - L-ring deformation in arch-shape

Type B (produced by Tohatsu Co.) - Two cylinders ($D \times S = 66 \times 64 \text{ mm}$), 440 cm^3 , air-cooled snowmobile engine.

Pistons and rings for the experiment were produced in special form and size to serve each purpose. These engines ran at the conditions of minimum spark advance and leanest air-fuel ratio for best torque; each lubricant-fuel ratio was about 1:30.

INFLUENCE OF RING SHAPE AND GROOVE POSITION -

Engine A - The test engine piston had three compression rings. The test was carried out using the three arrangements of the piston ring as shown in Fig. 14. The engine performance of Fig. 15 was obtained. It was found that each arrangement does not have the same maximum power, but the

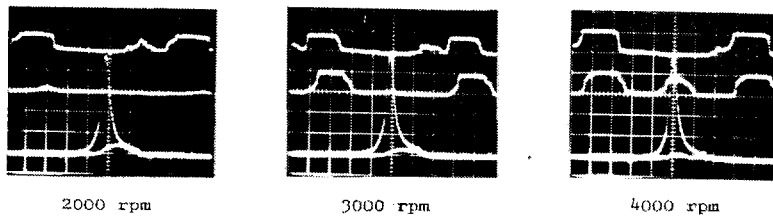

Fig. 12 - Movement of a weak L-ring (as a top ring) under full load

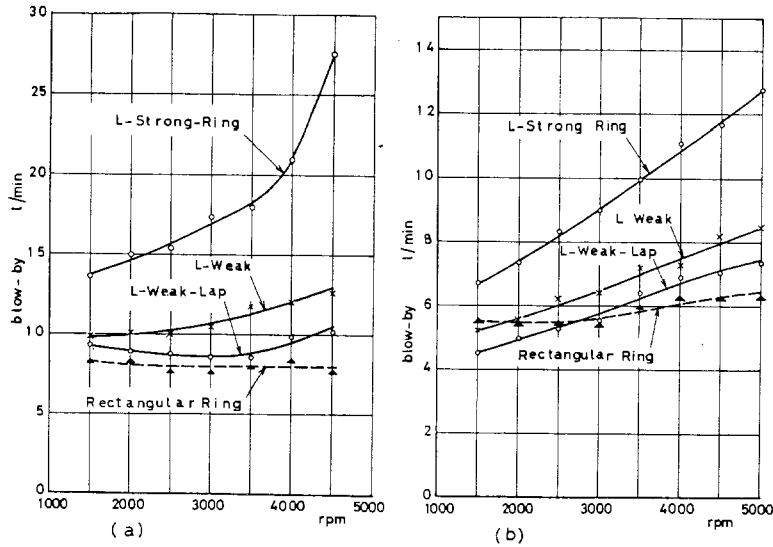

Fig. 13 - Amount of blowby in 1300 cm³ automobile engine with one compression-ring piston. A - Full load; B - Half load

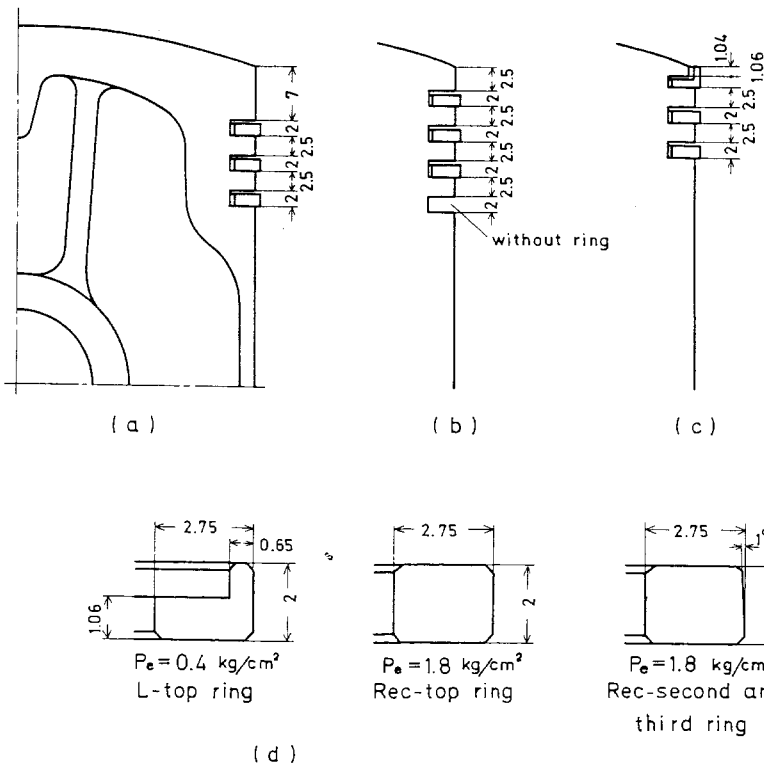

Fig. 14 - Test pistons and rings for engine A. A - Rectangular top ring, lower position; B - Rectangular top ring, upper position; C - L top ring; D - Ring cross section

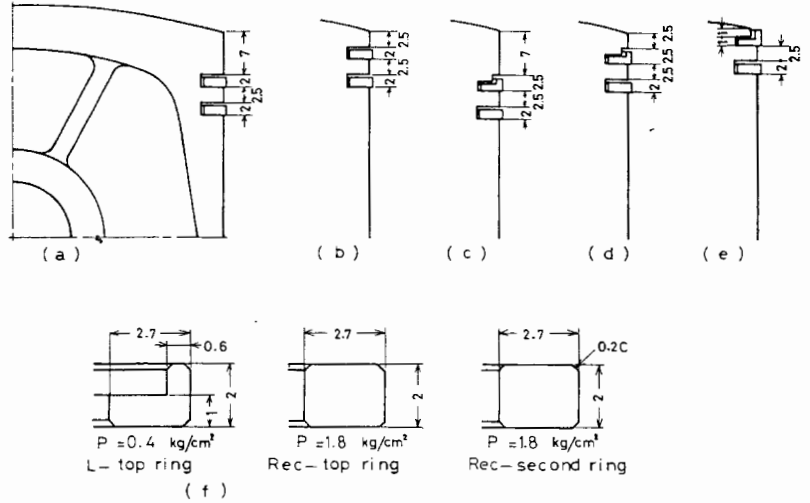

Fig. 16 - Test pistons and rings for engine B. A - Rectangular-7 mm; B - Rectangular-2.5 mm; D - L-2.5 mm; E - L-ring; F - Ring cross sections

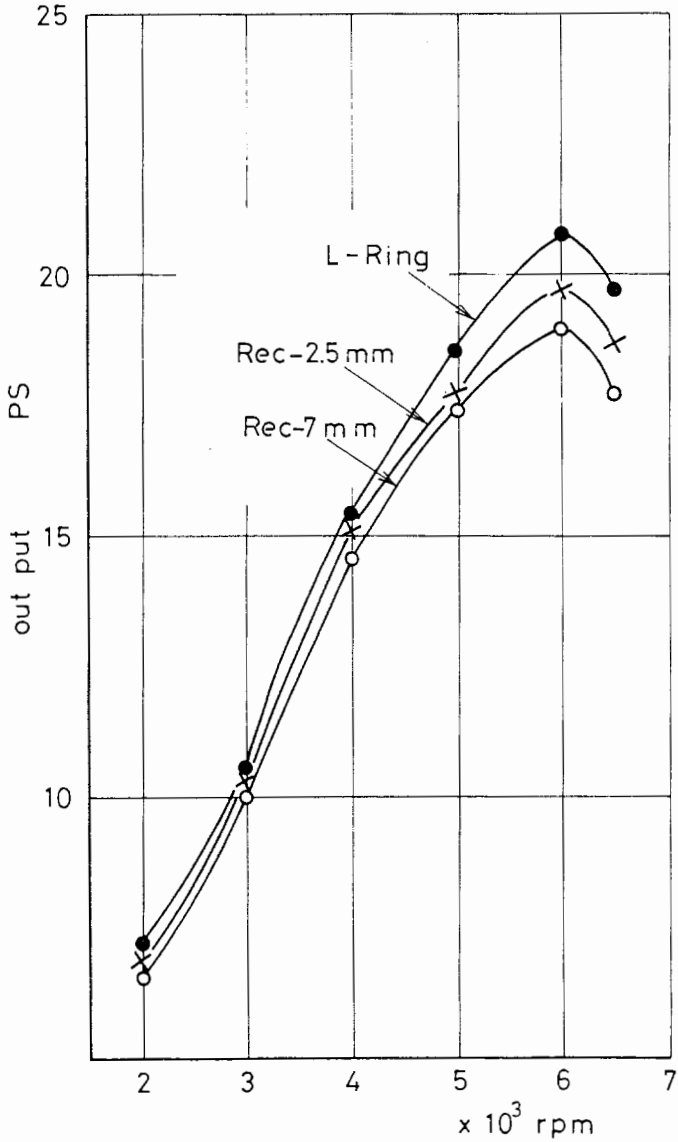

Fig. 15 - L-ring effect on maximum power in engine A

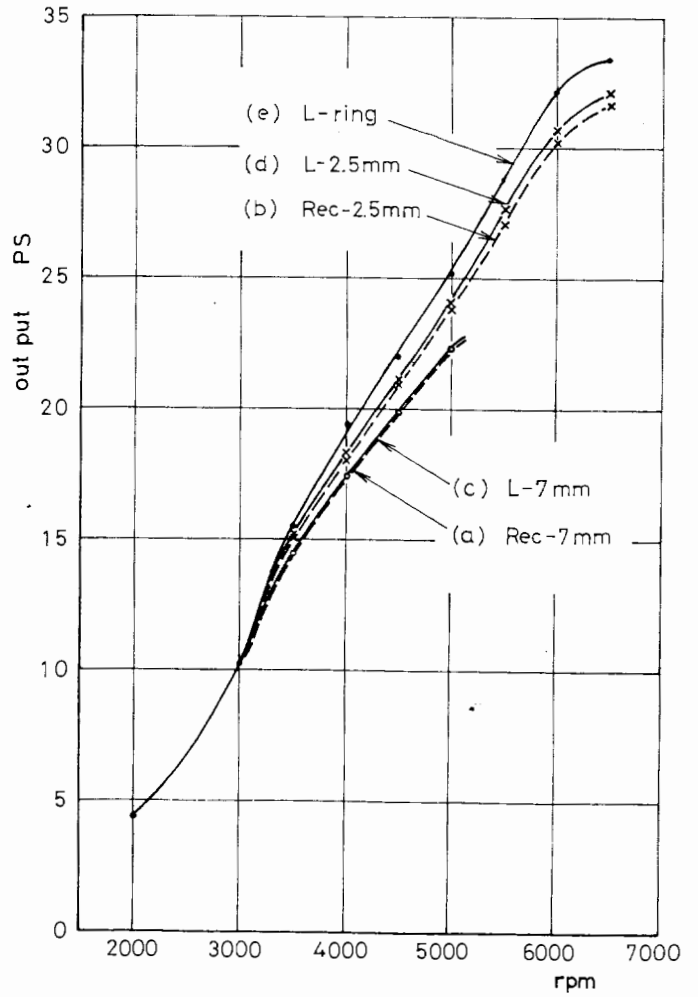

Fig. 17 - Ring effect on maximum power in engine B

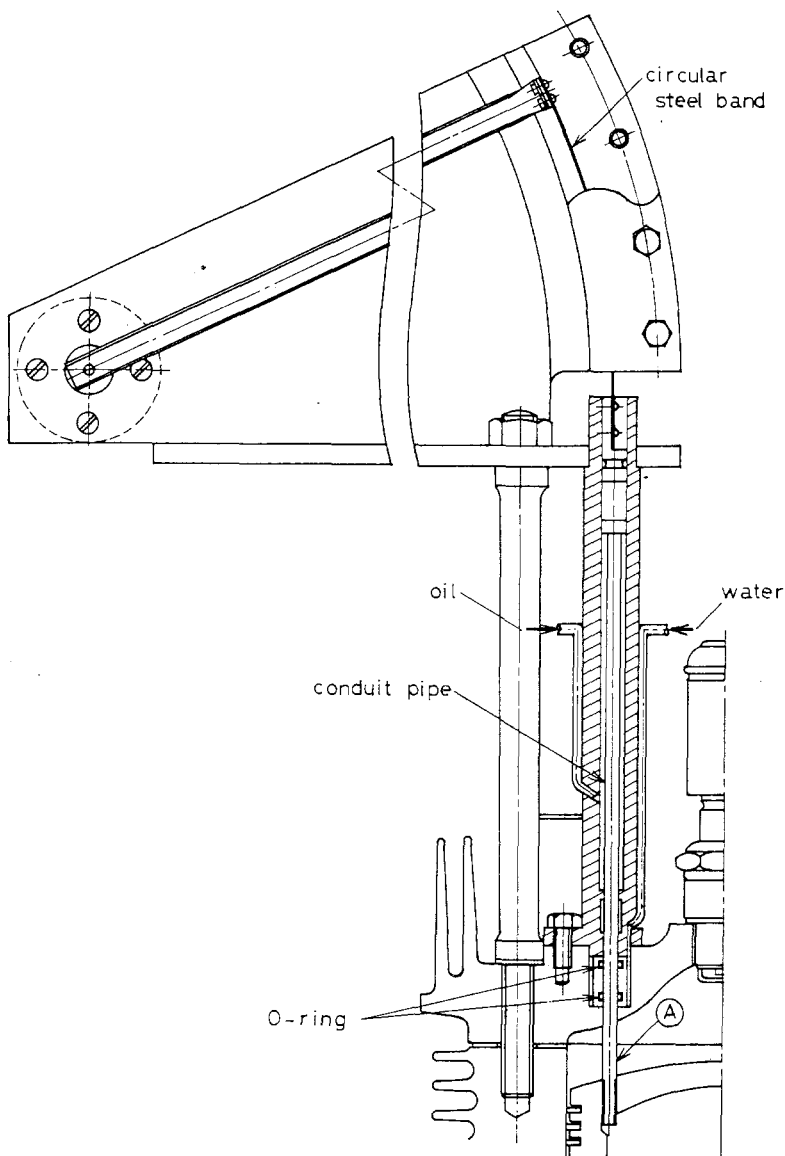
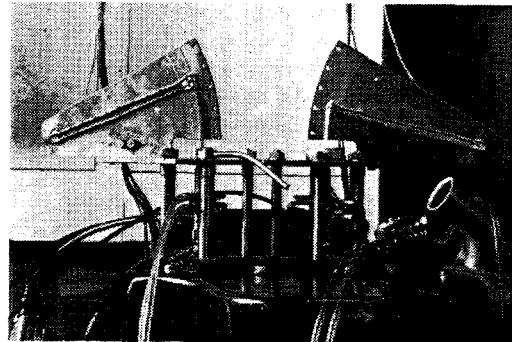
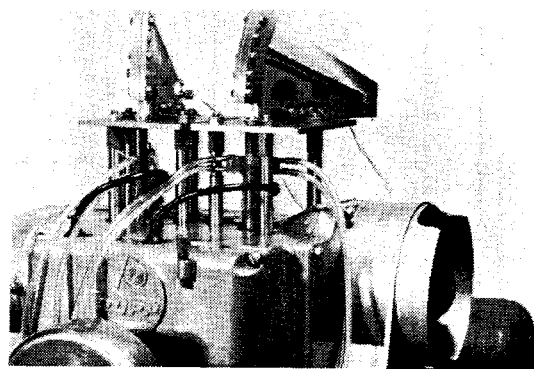

Fig. 18 - Combustion chamber across and circular band method used in this experiment



A



B

Fig. 19 - Two sets of piston temperature measurement device; A - Engine A; B - Engine B

L-ring is superior to the rectangular ring. Another important matter is that the engine with the upper position of the ring has much more power than with the lower position. Therefore, the usefulness of the L-ring is caused by either its L-shape or the fact that the L-ring can be positioned at the uppermost of piston shoulder.

Engine B - The piston of this engine had two compression rings. The ring arrangements of the test pistons are shown in Fig. 16; (A) is the lower position of the rectangular rings, (B) the upper one. In (C) and (D), the L-top ring is in the same positions respectively as (A) and (B); (E) is in the usual L-ring position.

As a result, a performance as shown in Fig. 17 was obtained, clarifying the following:

1. The higher the ring position, the more power is obtained regardless of the ring shape.
2. When the position is 7 mm lower than the upper edge,

the engine cannot run for a long time at a speed higher than about 5000 rpm because of potential seizure.

3. L-ring output is a little greater than with the rectangular ring at the same position.

L-RING EFFECT ON THE PISTON TEMPERATURE

TEMPERATURE MEASUREMENT OF THE PISTONS - Temperature measurement of the high-revolution two-stroke engine was difficult because the connection of lead wires between the piston and the stational place was not easy.

In this experiment "Combustion Chamber Across and Circular Band Method" (4, 5) was used. The thermocouple wires of iron and constantan were 0.15 mm in diameter, enamelcoated and glasswool was wound on them. A spherical hot junction of 1 mm in diameter was made by silver soldering. Each hot junction was plugged onto the piston surface. Thermocouple

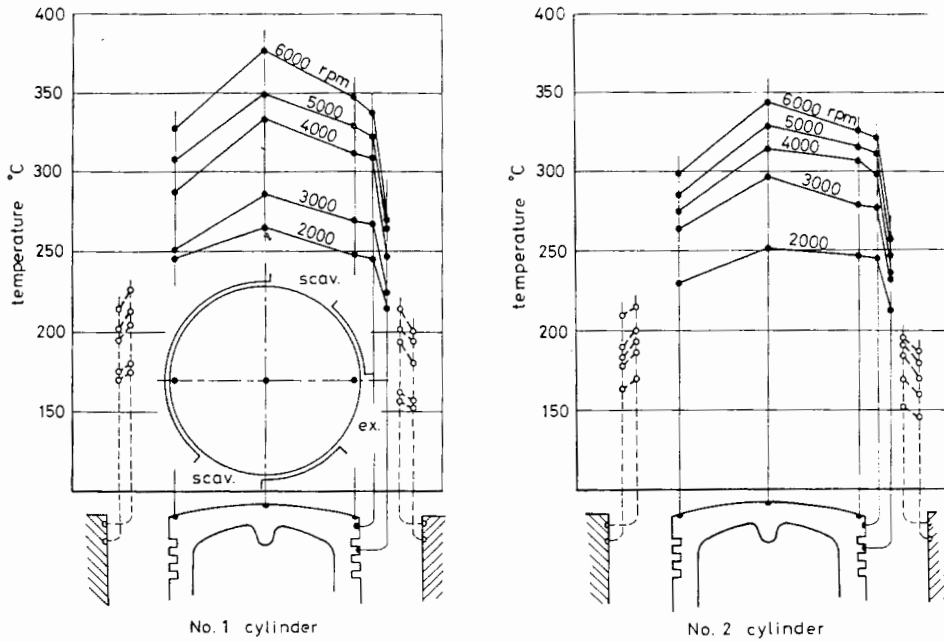

Fig. 20 - Comparison of each piston and cylinder temperature in full throttle

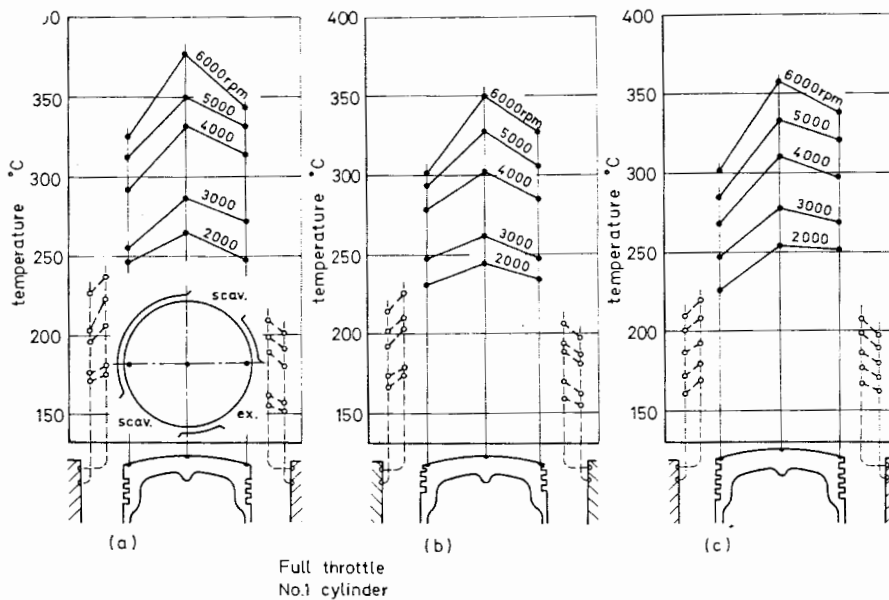

Fig. 21 - L-ring effect on piston temperature. A - Rectangular - lower; B - L-ring; C - Rectangular - upper

wires were cemented with thermostable bond in the conduit pipe which was fixed to the piston head, so the pipe reciprocated across the combustion chamber. The wires were stuck on a circular steel band from the top of the pipe to the stationary place (Fig. 18). The weakest endurance point of this apparatus was to overheat a part of the pipe just above the piston head of Fig. 18.

Fig. 19 shows an exterior view of this apparatus installed on engine A and B, each of which used two sets to measure the temperatures of two pistons.

Engine A - One example of the measuring temperature is shown in Fig. 20 from which two important matters are

found: first, that each temperature of two pistons is not the same, and that the maximum difference attains about 30 C; second, at maximum power, a part of the piston attains the critical temperature for seizure.

Fig. 21 shows the cooling effect of L-ring on the piston. Certainly, the piston with the L-ring has lower temperatures, and the piston with rectangular rings at the upper position also has lower temperatures than at the lower position. Comparing the temperatures of a piston under the same power, the temperature difference becomes much larger (Fig. 22).

In order to understand the heat flow in the shoulder part of the piston, an isothermal chart was obtained by hardness

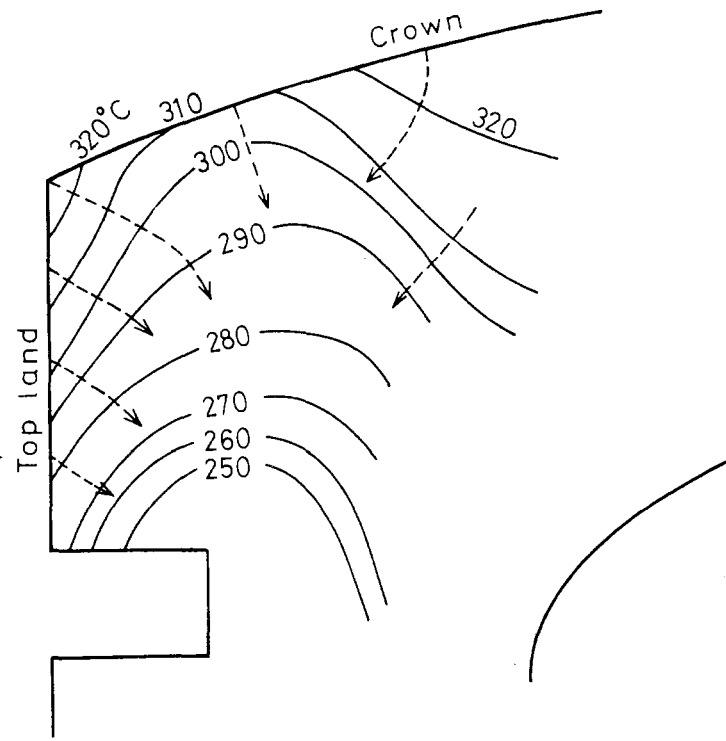

Fig. 23 - Isothermal chart on rectangular-lower piston

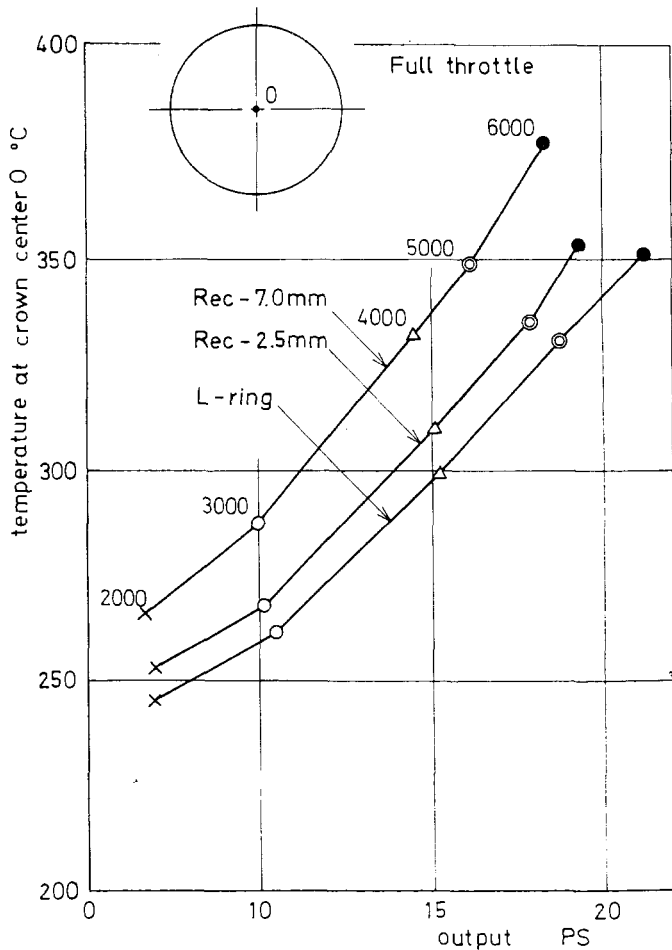

Fig. 22 - Piston temperature against power output

method. Fig. 23 is the result in the case of the piston with rectangular ring in the lower position. It is made clear from this that the heat flows into the piston not only from the crown surface, but also from the top land. Each piston with rectangular-lower, rectangular-upper, and L-ring has an area of the top land peripheral surface of 13.5 cm^2 , 5.8 cm^2 , and 2.0 cm^2 , respectively. On the other hand, the area of crown surface is 29.7 cm^2 . The further up the piston ring, the more effective the cooling of the piston. The first reason for this is the flow path of heat from the crown surface to the piston ring is short. The second reason is the amount of heat inflow from the top land to the piston is reduced. Therefore, it is certified that the cooling effect of the L-ring is caused by the situation of the ring, but is not caused by the sectional shape of L-ring.

Engine B - Using the pistons with lower positioned rings, as it was in danger of seizure during the high speed and long period running, the temperature measurement experiment was limited to the engine speed at which the maximum temperature reached about 370 C . The piston with 7 mm depth ring was limited to the 4500 rpm maximum speed. From these experimental results, temperature distributions are compared with those of each ring position and each ring shape in Fig. 24. It is clear that the lower the position of the rings, the higher the piston temperature becomes. The temperature on the crown, especially, has a large difference. Then the 7 mm depth ring position could not be used practically in this engine. When the ring positions of the L-ring and the rectangular ring are the same, the piston temperature of L-ring is almost the same or a little higher.

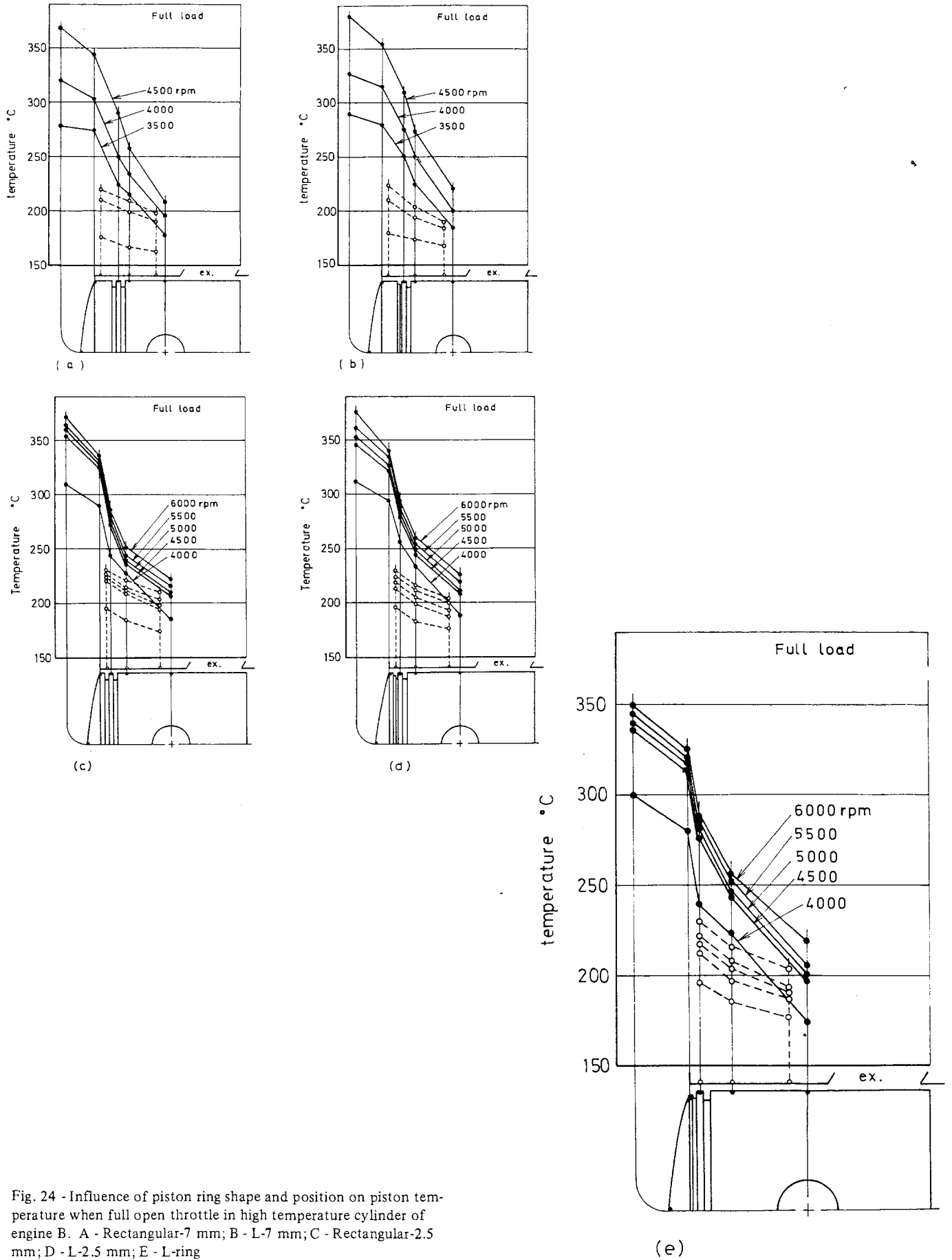

Fig. 24 - Influence of piston ring shape and position on piston temperature when full open throttle in high temperature cylinder of engine B. A - Rectangular-7 mm; B - L-7 mm; C - Rectangular-2.5 mm; D - L-2.5 mm; E - L-ring

CONCLUSION

1. During the operation of a recent air-cooled two-stroke gasoline engine near maximum power, the piston temperature reaches the critical temperature—350-370 C at the crown center. In the critical circumstance, the rubbing surfaces of the piston, cylinder, and ring, and the lubricating oil are deteriorated from the lubricating standpoint. Then the frictional resistance increases, and the piston sometimes falls into the seizure. Therefore, the more the piston is cooled, the more power that can be obtained safely.
2. The L-ring has more of a cooling effect than the usual rectangular ring.
3. The cooling effect of the L-ring is caused by its uppermost position in the piston shoulder, but it is not caused by its cross-sectional shape.
4. When the ring is in the upper position, the piston crown temperature becomes lower not only because of the short path of the heat flow from the piston head to the ring, but also the decrease in heat inflow area from the top land.
5. The large tension L-ring is inferior in sealing effect because of its arch-shape deformation. So the tension of the L-ring must be as weak as possible.
6. At the position coincident to that of rectangular ring, the piston temperature of L-ring was a little higher. Nevertheless, the output of L-ring was slightly greater. It seems that the greater output of L-ring was obtained by reason of its small elastic pressure.

SUMMARY

For the research of the L-ring effects on the performance of the high-output air-cooled two-stroke gasoline engine, the experiments on the sealing and cooling effect of the L-ring

were carried out comparing it with usual rectangular ring. The following results were obtained:

1. The piston reaches so high a temperature that the rubbing surfaces of the piston and the lubricating oil are deteriorated. Then the frictional resistance increases and, the piston sometimes falls into the seizure.
2. The L-ring has more cooling effect, so it can increase the engine power safely.
3. The L-ring effect does not depend on its cross-sectional shape, but upon its position in the piston because it can be positioned at upper edge of the piston shoulder.
4. Cooling effect of the piston with upper positioned rings is caused by not only shortening the path of the heat flow from the head to the ring, but also decreasing the heating area from the top land.

REFERENCES

1. P. De K. Dykes, "Piston Ring Movement during Blow-by in High-Speed Petrol Engines." *Trans. Inst. Mech. Engrs.*, Vol. 2 (1947-1948), No. 71.
2. S. Furuhashi and M. Tsuruta, "A Dynamic Theory of Piston-Ring Lubrication (4th Report, Load)." *Transactions of the JSME*, Vol. 27, No. 178 (1962), pp. 919-926.
3. S. Furuhashi and M. Hiruma, "Axial Movement of Piston Rings in the Groove." Presented at the 27th ASLE Annual Meeting, Houston, May 1-4, 1972.
4. S. Furuhashi, "The Temperature of a Crankpin Bearing of an Automobile Engine." *ASLE Transactions* 10 (1967), pp. 203-213.
5. S. Furuhashi, T. Tada, and T. Nakamura, "Some Measurements of the Piston Temperatures in a Small Type Gasoline Engine." *Bulletin of JSME*, Vol. 7, No. 26 (1964), pp. 422-429.



This paper is subject to revision. Statements and opinions advanced in papers or discussion are the author's and are his responsibility, not the Society's; however, the paper has

been edited by SAE for uniform styling and format. Discussion will be printed with the paper if it is published in SAE Transactions. For permission to publish this paper in full or in part, contact the SAE Publications Division and the authors.

Society of Automotive Engineers, Inc.

TWO PENNSYLVANIA PLAZA, NEW YORK, N. Y. 10001